



INSTALLATION INSTRUCTIONS

MODEL 600HS



L – Housing



S – Housing

ASSEMBLY INSTRUCTIONS

- 1. Unpack your unit and remove all packing from the blower and motor assembly.**
- 2. Remove both housing access doors.**
- 3. VERY IMPORTANT NOTE! MAKE SURE THE BLOWER WHEEL SPINS FREELY.**
- 4. From the filter section, remove the wire framed pre-filter.**
- 5. Locate the two HEPA filter holding strips that also act as a tray for the carbon filter and pre-filter. Remove the two hex nuts and associated screws on both holding trays and remove the trays from the housing.**
- 6. Remove the hex head screws that are in the gasket material on the BOTTOM (motor) section of your unit. The BOTTOM & TOP (filter) sections are symmetrical, so they can be rotated 360 degrees so the discharge can be pointed in four different directions to accommodate any installation configuration. This allows for best directional location for the TOP section filter access door. MAKE SURE THE DISCHARGE DIRECTION IS CORRECT FOR YOUR APPLICATION BEFORE ASSEMBLING. Align the sections as desired. Place the TOP section on the BOTTOM section, align the holes and tighten the hex head screws.**
- 7. Insert HEPA filter. BE CAREFUL TO NOT PUNCTURE THE HEPA MEDIA. The gasket should be toward the motor unit. Center the gasket over the knife-edges so that it is even on all four sides. Replace the two HEPA holding trays.**
- 8. Remove the wrapping from the carbon filter and slide the carbon filter and pre-filter back into the trays and replace the access door.**

Please look at the attached "typical installation" drawings. The inlet duct should be connected to the main return air duct leading to the heating/cooling system, and the discharge duct should be connected to the point where the return air duct enters the heating/cooling fan area.

ALWAYS INSTALL THIS SYSTEM IN A BY-PASS CONFIGURATION.

MATERIALS NEEDED FOR COMMON HVAC INSTALLATIONS

1. Section of 12" (14" for 1200/2000 units) diameter sheet metal (recommended) or flex duct. You will need 3' to 6' for most installations.
2. Section of 10" (14" for 1200/2000 units) diameter sheet metal (recommended) or flex duct. You will need 6" to 24" for most installations.
3. 12" collar (14" for 1200/2000 units) for connection to return air duct.
4. 10" collar (14" for 1200/2000 units) for connection to fan return side of HVAC unit.
5. 4" by 18" (4" by 24" for 1200/2000 units) piece of sheet metal for Air Scoop. Or a prefabricated damper. This is recommended to be installed with every unit.
6. Sheet metal screws, duct tape or metal tape. 12 gauge electrical wire for power to unit.
7. Thermostat wire.

INSTALLATION OF THE DUCTING

Select the proper location for the attachment of the inlet and discharge ducts. Try to keep a minimum of 6 feet between the inlet and discharge openings. This will prevent the Pure Air Systems' filtration unit from recycling the same air. Cut the openings in the existing return air duct. We recommend an air scoop be placed inside of the return air duct so that it directs air into the inlet duct of your filtration system. You can use a damper as an air scoop. Make sure the damper is angled to direct the air from the return air duct into the inlet duct of your filtration system.

Use sheet metal screws, duct tape or aluminum tape to attach the duct sections to the collars on the inlet of the unit and the air return. Make sure there are no air leaks. Repeat this same procedure for the discharge duct. Make sure all connections are tight and taped.

ELECTRICAL WIRING

NOTE: ALWAYS FOLLOW ELECTRICAL CODES FOR YOUR AREA. We recommend a dedicated 15 amp service for all of our air filtration systems. The conduit connector is designed for EMT conduit or Romex cable. Wire the black, white and green (ground) wires through the conduit connector to the black, white and green wires inside the unit.

The 600HS unit requires 120 volt, single phase service. It uses a 1/3 HP 5 amp, capacitor start, single speed motor. The system is designed to run 24 hours a day. You can control the 600HS unit in two ways:

- 1.) Use a pressure switch or sail switch located in the main return air duct. In this way, anytime the HVAC fan is running the 600HS unit will run.
- 2.) Use the lighted on/off switch to control unit. You can run the unit anytime or all the time using this approach. The 600HS units are designed to run 24/7.

We recommend you run your HVAC fan all of the time. This will enable you to circulate the air constantly through the house and air filtration system. This will also help maintain a more constant temperature throughout the living space.



General Commercial Guidelines for Replacing Filters

- **Pre-filter once a month**
- **Carbon filter every 6 months**
- **HEPA filter once a year**

6115 Guion Rd.
Indianapolis, IN 46254
800.869.8025 or 317.291.4341
Fax 317.291.4381

pas@pureairsystems.com



General Residential Guidelines for Replacing Filters

- **Prefilter 3 months**
- **Carbon filter every year**
- **HEPA filter 2.5 to 3 years**

6115 Guion Rd.
Indianapolis, IN 46254
800.869.8025 or 317.291.4341
Fax 317.291.4381
pas@pureairsystems.com

Pure Air Systems Limited Warranty

Your Pure Air Systems product has been manufactured tested and inspected in accordance with carefully specified engineering requirements and is warranted to be free from defects and workmanship in accordance with the terms and conditions as set forth below.

Duration of Warranty and To Whom Extended

This Limited Warranty shall be for one year on the motor and three years for the other electrical components and blower. It does not cover the filters in the system as they are a standard maintenance item.

Exceptions and Exclusions from Warranty

Those products which incorporate an electrical motor are required to be used on electrical current as indicated on the rating plate. This Limited Warranty does not apply to products which have been subject to use on electrical current other than indicated on the rating sticker of the product.

This Limited Warranty does not apply to products which have been subject to improper, unreasonable or negligent use, abuse, or the use of parts or accessories which are not approved by Pure Air Systems.

If repair is done on your equipment by anyone other than those designated as authorized to perform such work, Pure Air Systems at its sole option, may determine that this Limited Warranty will not apply.

Procedure to be taken to obtain Performance of Warranty

To secure repair of the product or any warranted parts under the Limited Warranty, the following procedures shall be taken:

- Contact Pure Air Systems or the dealer that installed your system
- It is important that the model number and serial number of the system be provided to Pure Air Systems to ensure the product falls within the warranty time frame.
- The inoperative component(s) or warranted parts, together with satisfactory evidence of the purchase date, must be delivered, with shipping and delivery charges prepaid to Pure Air Systems.
- Upon compliance with the above procedure, all warranted defected parts will be repaired or replaced. Pure Air Systems will pay for return shipping and cost of replacement parts.

NO REFUND OF PURCHASE PRICE

Pure Air Systems will not, as a matter of its Warranty Policy, refund the customer's purchase price. This limited warranty gives you specific legal rights and you may also have other rights which vary from state to state.

NO CLAIMS FOR CONSEQUENTIAL OR OTHER DAMAGES WILL BE ALLOWED AND THERE ARE NO OTHER EXPRESS WARRANTIES EXCEPT THOSE EXPRESSLY STIPULATED HEREIN. SOME STATES DO NOT ALLOW LIMITATIONS ON HOW LONG AN IMPLIED WARRANTY LASTS OR THE EXCLUSION OR LIMITATION OR INCIDENTAL OR CONSEQUENTIAL DAMAGES. THEREFORE, THE LIMITATIONS OR EXCLUSIONS MAY NOT APPLY TO YOU.

Pure Air Systems
6115 Guion Road
Indianapolis, Indiana 46254
Phone# 800-869-8025
Email: pas@pureairsystems.com

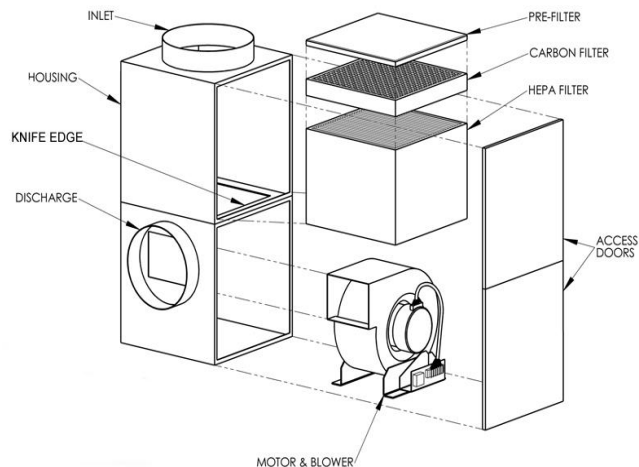

6115 Guion Rd.
Indianapolis, IN 46254
800.869.8025
317.291.4341

e-mail: pas@pureairsystems.com
www.pureairsystems.com

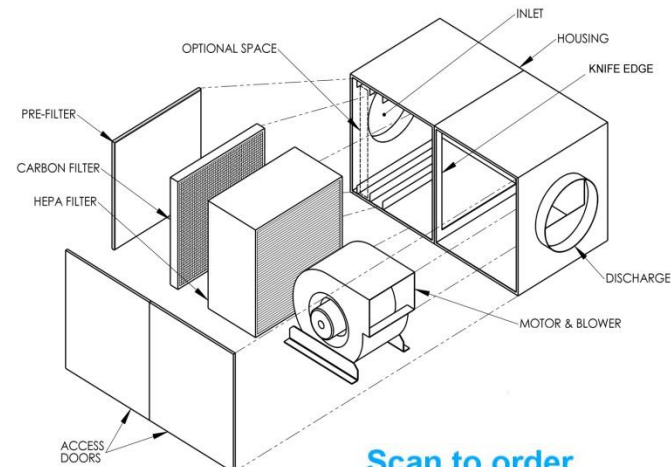

Scan to order



Replacement Filters

FILTER MAINTENANCE

WARNING

(Before changing any filters always turn power off to unit by switching the lighted rocker switch located on the discharge or motor section of the unit to the off or down position.)

PREFILTER: (change every 3 to 4 months unless used in commercial applications.)

1.) Ring panel prefilter is located on top or next to the carbon filter. Simply slide the prefilter out and replace with new prefilter. Make sure white side is facing up or toward the airflow. Replace filter door and turn lighted rocker switch back to the on or up position.

CARBON FILTER: (change every 9 to 12 months unless used in commercial applications.)

1.) Carbon filter is located just under the prefilter or between prefilter and HEPA filter. Some housings you'll have to remove prefilter before you can remove and replace carbon filter. Replace prefilter on top of carbon filter. Replace filter door and turn lighted rocker switch back to the on or up position.

HEPA FILTER: (change every 2.5 to 3 years unless used in commercial applications.)

- 1.) Remove prefilter and carbon filter.
- 2.) Remove nuts and bolts (two on each side) that attach hold down channels. On some housings you'll need to loosen the set screws (top and bottom) and remove the bolts to the compression brackets. Remove both channels and or brackets. Lift HEPA filter out of housing.
- 3.) Carefully place new HEPA filter back in housing. Lift and position HEPA filter with gasket side facing down sitting evenly on metal knife edge on all four sides.
- 4.) Replace channels and or brackets with bolts, nuts or set screws to their original locations and tighten them. Replace carbon and prefilter.
- 5.) Replace filter door and turn lighted rocker switch back to the on or up position.